

I. BOLT INFORMATION

1. Bolt Head Type:

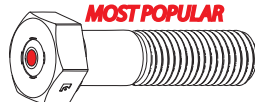

Hex Head Cap Screw

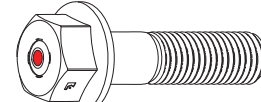

Hex Head Flange Bolt

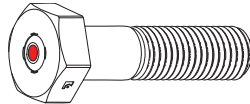

Heavy Hex Cap Screw

Other _____

2. Dimensions:

_____ - _____ x _____
Nominal Diameter TPI/Pitch Length

3. Grade:

Grade 5/Class 8.8 Grade 8/Class 10.9 Other _____

4. Finish:

Plain Clear Zinc Yellow Zinc
Other _____

5. Thread Length:

Partial Full Custom _____

6. Additional Specifications: _____

II. VISUAL INDICATION SYSTEM

Standard Indicator Design - Shows "Tight" color at 70% of fastener modified proof load.

Custom Indicator Design - Shows "Tight" color as requested (limits apply).

The Visual Indication System measures tension. If required tension is unknown, an installation torque value may be substituted.

Requested Indicating Tension
(klbf, kN)

OR

Requested Installation Torque*
(lbs-ft, Nm)

AND

Assumed Nut Factor**

*Torque values will be converted using the equation $T = KFD$, where T =torque, F =force, D =diameter, and K =nut factor.

**Nut factor will be assumed to be 0.2 unless otherwise noted.

III. APPLICATION INFORMATION

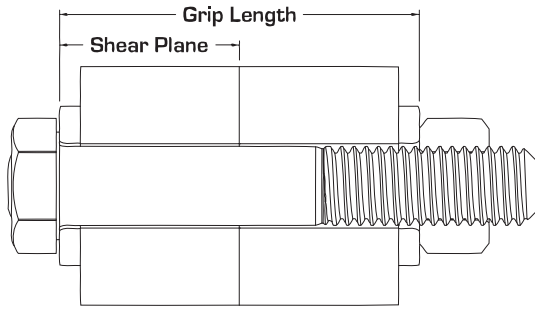

Type 1: Clearance Hole

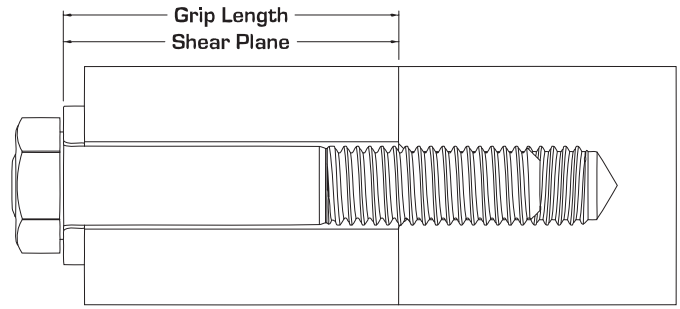

Type 2: Blind Hole

- | | | |
|----------------------|-----------------------|----------------------|
| 1. Bolted Joint Type | <i>Clearance Hole</i> | <i>Blind Hole</i> |
| 2. Grip Length | _____ | 3. Shear Plane _____ |
| 4. Environment | _____
_____ | |
| 5. Comments | _____
_____ | |

IV. OPTIONS

- | | | |
|--------------------------|-------------------------------|-----------------------------------|
| <i>Protective Recess</i> | <i>Contamination Seal</i> | <i>Retro-Reflective Indicator</i> |
| <i>Made in USA</i> | <i>Material Certification</i> | <i>Plating Certification</i> |

V. ORDER INFORMATION

- | | | | |
|--------------------------|-------|-----------------------|-----------------------|
| 1. Quantity | _____ | <i>Exact Quantity</i> | <i>Expedite Order</i> |
| 2. Expected Annual Usage | _____ | | |
| 3. First Name | _____ | 4. Last Name | _____ |
| 5. Company | _____ | 6. Position | _____ |
| 7. Phone | _____ | 8. Email | _____ |
| 9. Country | _____ | 10. Postal Code | _____ |